



Name _____

Date _____

Test on Chapters 8 and 10

<http://www.gmajormusictheory.org/Fundamentals/workbooks.html>

1. Write the key signatures for these major keys.

instructor writes keys

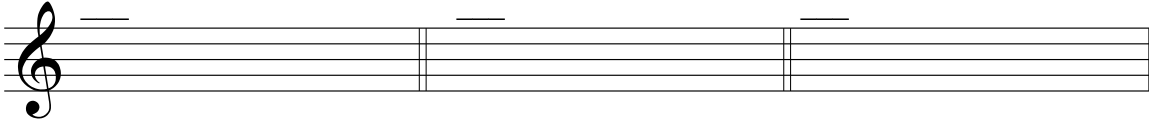

2. Write the full name for these intervals. You may abbreviate the specific name.

instructor writes intervals



3. Write the top note of the given intervals.

instructor writes bottom note and interval name

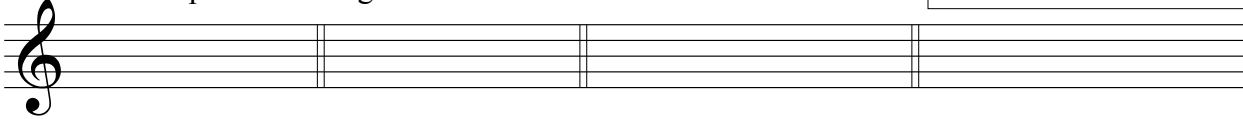

4. Identify these triads as major, minor, diminished or augmented.

instructor writes triads

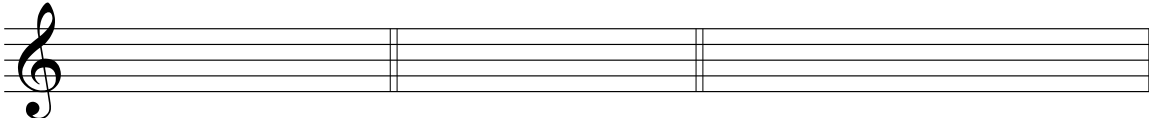

5. Construct triads above these notes.

instructor writes roots and triad types

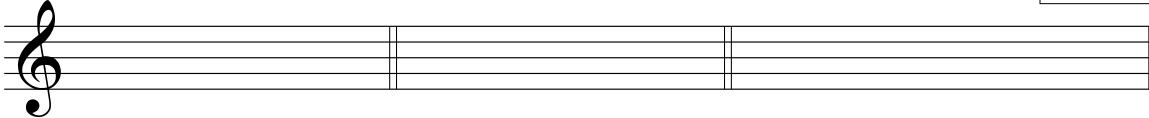

6. Construct triads given the third or fifth.

instructor writes and labels 3rd or 5th; writes triad type

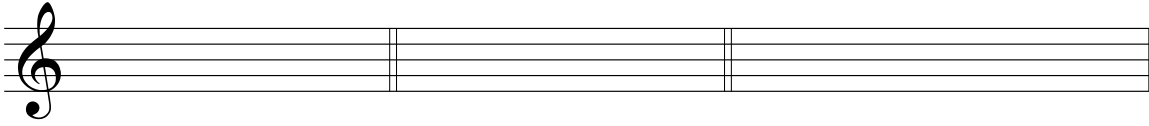

7. Identify the triads as major, minor, diminished or augmented.

instructor writes *key signature* and triad

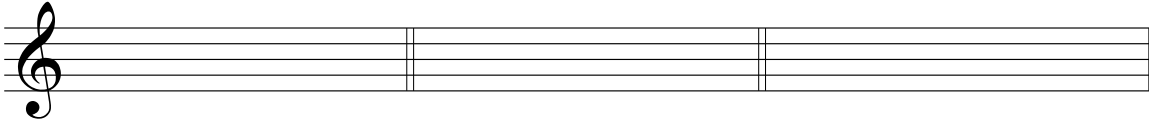

8. Write sharps and flats next to the appropriate notes in this chart to make all the triads major.
Circle the triads that need no alterations.

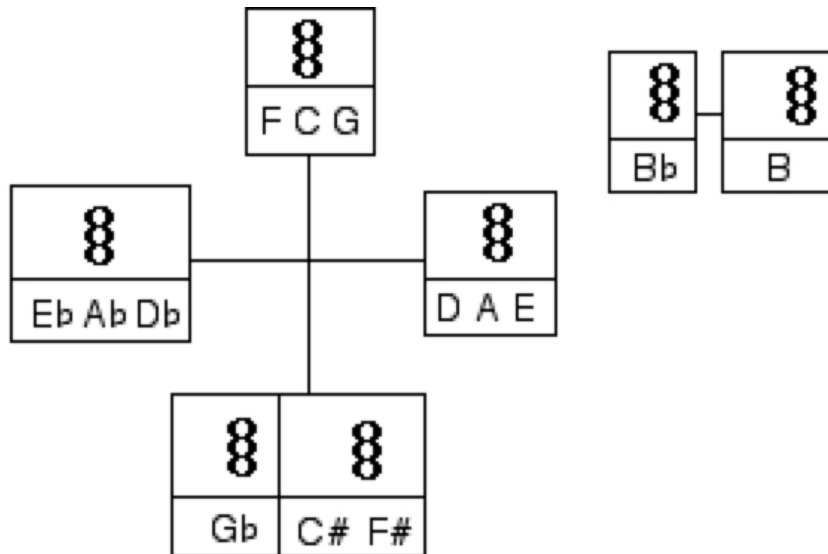

In 1 - 4 each problem = 3
 In 5 - 7 each problem = 4
 In 8 each triad = 2 (14 total)
 Test = 45 + 36 + 14 = 95